

MOBILE MT



The basics of mobile data recording

Operating environment: Mobile data recording unit for storage and logistics (stacker terminal)

- The stacker terminals themselves should be able to make do with the smallest outer dimensions, while offering the largest possible LCD sight range.
- The mobile industrial PCs should have a robust ALU/steel housing, but weigh as little as possible.
- The CPU unit should have the highest performance but the lowest power consumption or heat discharge.

FORSIS GmbH developed the MOBILE series with the goal of finding the optimal solution from these contradictions and opposites. The devices perfectly combine high performance with a low weight and very small sizes.

Antenna technology according to IEEE802.11 ac/g/n

FORSIS offers a dedicated MIMO (Multiple-Input-Multiple-Output) antenna for all device assemblies. MIMO antenna systems offer higher data transmission rates, a larger reach and are not only "immune" to multipath scattering, but even use it. A MIMO system is therefore particularly suitable for use in industrial inner areas without any direct visual connection between a PC and an AP/router. In addition to implementation of the n standard, our target was to develop a robust antenna (protection class IP65). For more about this, see the special data sheet on the antenna.



The special features

- Uniform IPC platform with the latest CPU technologies
- The device is set up compact and vibration-protected
- Minimal wiring and no mechanically moved components
- **Capacitiv MULTITOUCH according to the LCD size**
- Analog resistive touch panel version is also available
- The protection type [EN60529] is IP65 on the front, IP54 on the connection side
- The housing is made of steel sheet, powder-coated on the outside, galvanized on the inside
- Approvals: CE, FCC, vibration and shock test according to DIN EN 60721-3-5/5M3
- Temperature range: -10 °C to 50 °C by default, expansible to -30 °C
- Assembly takes place through various holder systems, adaptation by VESA 100
- The cable is fed in from below, protected by cover; tension relief per cable
- Power supply: typically 24 V DC with an input range 10-32 V DC
- Expansion options: Keyboards, scanners and their supply



Product information

MOBILE MT - Forklift terminal
with capacitiv Multitouch Panel

Technical features

Measures and weight

Information on the dimensions in mm
to the weight in kg

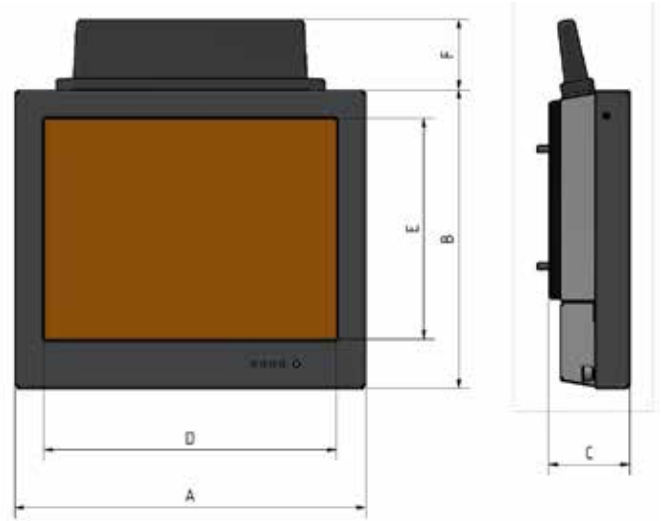

MOBILE	Overall dimensions			Active Touch field		Weight
	A - Width	B+F - Height	C - Depth	D - Width	E - Height	
1000	267	236 + 60	70	216	164	3,6
1200	300	266 + 60	70	246	186	3,8
1500	365	305 + 60	79	300	232	4,6

Mainboard and CPU variants

Type MOBILE	1000	1200	1500
LCD diagonal / format	10" / 4:3	12" / 4:3	15" / 4:3
resolution	SVGA/XGA	XGA	XGA
Touchscreen / interface / IP protection class	PCAP Touch Panel / USB HID oder seriell / IP67		
Motion sensor for LCD or Touch panel control		■	
WLAN INTEL Wi-Fi 6 AX200 MU IEEE 802.11 a,c,n, ax 2x antenna interface		■	
Bluetooth 4.2, In combination with the WLAN adapter		■	

CPU INTEL® Celeron® 6305E TGL	TIGER LAKE	■
CPU INTEL® I3® 1115G4E TGL		■
CPU INTEL® I5® 1145G7E TGL		■
UEFI BIOS Support / TPM2.0		■ / ■
RAM / max. RAM / SSD MSATA M.2		8 GB / 32 GB / 128 GB
USB 3.1 Gen.2 / LAN		4x / 2x 1Gbit und 1x2,5 Gbit
optional interface: serial RS232		1x

Product information

Technical features

Touchscreen technology and front area



With the new design of the front section of the MOBILE MULTITOUCH, a lot of emphasis was placed on quality and „look and feel“. Check it out for yourself!

- Gloves - Working with almost all types of gloves is possible with the MULTITOUCH. However, it may be necessary to adapt to the glove thickness. This is done via a special adjustment in the touch controller.
- Standing water and the ball of the hand
- Moisture on the glass surface can also be ignored.
- Along with the palm rest, which can be hidden.

Power supply, connection and cable deployment



Power supply

Special features for voltage supply of the MOBILE series:

- Minimized power consumption of the overall system to the lowest values
- Power consumption in operation approx. 25 Watt
- Mains unit can handle up to approx. 65 Watt
- Power consumption on standby < 1 Watt
- Wide range input 10-32 Volt DC

Cable protection/tension relief - connection side

This carrier can be removed with a secured knurled screw.

Specifically: Simple and one-time installation of the cables.

The cable carrier remains at the site of use even when the device is replaced.

Protective cover - Rear view

To protect the plug-in connection, the entire connection side can be closed with a safety cover. The cover is secured with 2 studs and 2 knurled screws.



Optional integrated or external

LIFAI UPS unit

- Standby operation
- Bridges power outages of up to approx. 5 minutes
- Controls a timed controlled shut down



MOBILE MT - Forklift terminal
with capacitive multitouch panel

Technical features



Attachment and bracket

The secure mechanical fastening of data acquisition devices in use on mobile industrial trucks requires well thought-out and proven fastening systems. Shocks and vibrations must be absorbed. At the same time, the mounting systems must be flexibly mountable and easy for the operator to adjust.

The prerequisite for largely all mounting systems is now the VESA 100 standard on the device itself. This is always offered with FORSIS products in mobile use. For quick assembly, threaded stud bolts are set on the back of the device in a 100x100 mm square. The 10 mm thick aluminum carrier plate offers the ideal opportunity to distribute forces over the entire system.



Stand and wall bracket for the MOBILE device series

The stand and wall brackets from FORSIS are constructed in two parts. The same mounting bracket is always attached to the VESA 100 mount on the device itself. The stand or wall brackets, which are of different lengths, are attached to it. This also creates the pivot point for the vertical axis. The greatly shortened mounting bracket prevents the device from protruding far into the driver's area. Thus the field of vision is not impaired.

Device type according to LCD size	1000 /1200	1500
Stand bracket (height): Distance from the floor to the axis of rotation	167mm	200mm
Wall bracket (depth): Distance from the wall to the axis of rotation	100mm	110mm



RAM mount brackets

The RAM-MOUNT system uses ball joints in various sizes (see below), which are joined together with connecting elements to form a complete, very flexibly adjustable holder system.

The joints are movable and easy to adjust when the locking screw is loosened. As soon as the locking screw is tightened, the holder is fixed in its set position. To ensure the greatest possible stability, most of the parts are made of solid cast aluminum, some of high-strength plastic, are light and weatherproof. The metal balls of the ball joints are partially rubberized to dampen vibrations. Different ball system sizes can also be connected to one another.

The following recommendations apply when used on industrial trucks:

C-Ball: diameter 3.81 cm (1.5 inches) to 1.8 kg

D-Ball: diameter 2.25 inches (5.715 cm) to 4.5 kg

E-ball: diameter 8.57 cm (3.375 inches) to 7.56 kg

Headquarter
FORSIS GmbH
Schwanenstraße 5
D-88214 Ravensburg
info@forsis.de, www.forsis.de

Contact
D South +49 751 – 76414-0
D North +49 5066 - 900229 160
A / CH +43 5572 - 372709
D Fax +49 751 – 76414-366



Passing on and reproduction of this document, exploitation and disclosure of the contents are not permitted unless expressly allowed.

Violations obligate to damages. All rights reserved. Technical changes are reserved
FORSIS-MOBILE-MT-24-EN / 01.02.24